



SERVICE INFORMATION

DATE: June 1, 2006

ST-012-06

TO: All Coleman Evcon Service Managers
 All Field Service Supervisors
 All Regional Managers

SUBJECT: Defrost Control 031-01975-000 (S1-03101975000) SAP#10211

UNITS: BAUP-*042, BAUZ-*042

We had a few reports this past winter of the units listed above not defrosting completely. Reports were that the units exited the defrost cycle at too low a temperature, leaving a band of frost or a completely frozen over coil.

The issue seemed to be related to the operating temperature and humidity levels particular to the installed locations. The field reports were mostly from areas with high humidity, colder temperatures and a mountainous area, with wider swings in operating conditions from night – to morning – to day.

Norman Engineering put a unit into the test cells, duplicated the operating conditions and was able to see the same defrost issues as the field. Various changes were made to the sensor location and different defrost modules trying to get a clear coil under those conditions. By raising the termination settings slightly higher than the other 3 pin settings, they were able to attain a clear coil at the set ambient conditions.

The 031-01975-000 defrost module used on these units has (4) pin settings, of which only (3) were programmed and used. Engineering had the maker of the module program the 4th pin to duplicate the parameters of the test module that worked. This pin #4 would be designated a service pin for those applications that needed a longer defrost cycle. These new boards were introduced into the line the 2nd week April, 2006. Source One will stock the revised boards as the standard replacement.

The program settings for this module are as below:

1157-900 Model	031-01975-000	(SAP #10211)		
Jumper position	1	2	3	4
Coupling Assumed	100%	100%	100%	100%
Initiate 1	21°F @ 35°F amb.	25°F @ 35°F amb.	22°F @ 35°F amb	21°F @ 35°F amb.
Initiate 2	0°F @ 10°F amb.	0°F @ 10°F amb.	0°F @ 10°F amb.	0°F @ 10°F amb.
Temperature Inhibit (initiating defrost)	40°F (Coil)	40°F (Coil)	40°F (Coil)	40°F (Coil)
Timed Inhibit (between defrosts)	20 minutes	20 minutes	20 minutes	20 minutes
Terminate	40°F	40°F	32°F	55°F

The units come from the factory with the standard settings below:

BAUP/BAUZ-F036, 048, 060	Pin #1
BAUP/BAUZ-F024, 030	Pin #2
BAUP/BAUZ-F042	Pin #3
Service Pin	Pin #4

While this was specifically changed for the 3.5 ton unit, the pin 4 setting could be used for adjusting the defrost settings for any of the above listed product. I would review the factory setting for the model size and make changes to the next setting instead of going directly to the pin #4.

Before changing the pin setting, make sure the unit charge is correct, air flow is correct, and the liquid line sensor is good and making contact with the line. If these are ok, change the pin position to #4 and run through a cycle. There is a small COP loss for keeping the units in defrost for longer periods of time.

The New version of the S1-03101975000 board with the revised service Pin #4 is designated as a "B" version. Unfortunately the vendor failed to change the code to a "B" on the first shipment of new boards. However, the micro-processor was changed and will have a #279 label.

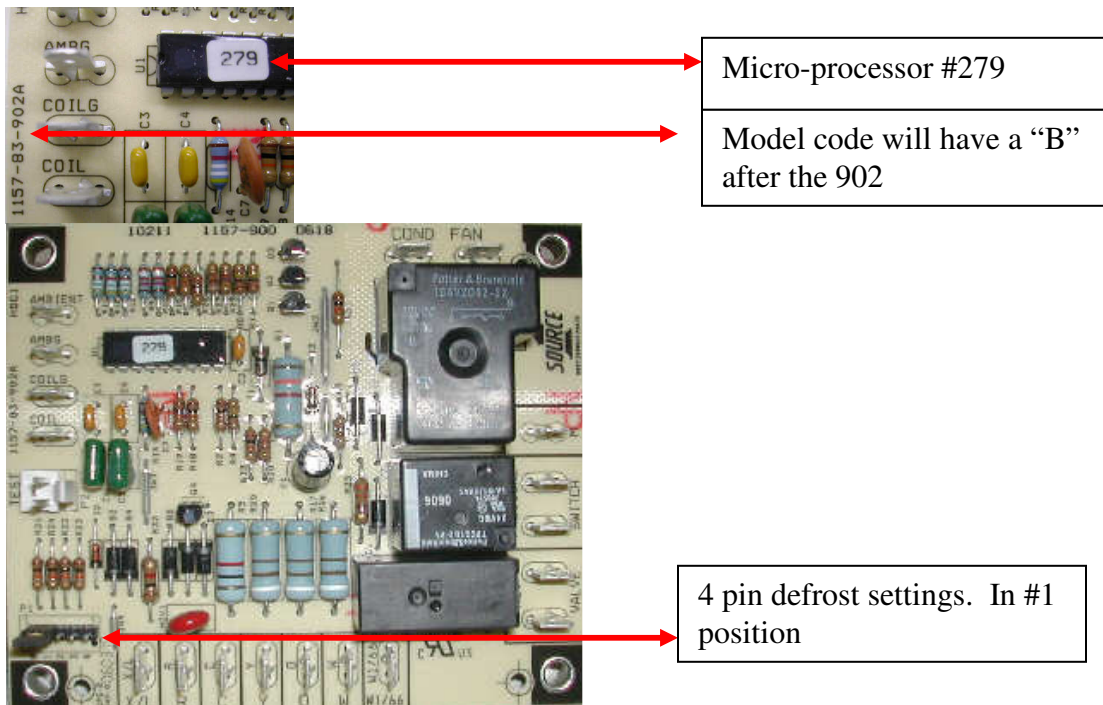

Since this is an application and location issue, there is no labor allowance associated with this letter. Boards would be covered under standard warranty.

Len Renfro
Len Renfro
Field Service Supervisor

Bernie Warning
Bernie Warning
Sr. Engineer, Norman